

---

## Service Bulletin

January 28, 2008

SB08-53-01

### TITLE

ENGINE COWLING ALIGNMENT INSPECTION AND MODIFICATION

### EFFECTIVITY

Model	Serial Numbers
172R	17280725 thru 17281262
172S	172S8202 thru 172S10006

### REASON

To provide a more detailed inspection of the engine cowling installation for alignment, fit, and clearance with the fuselage; and for cracks in the firewall. To provide modifications for the cowling shock mount attach brackets and engine baffle seals.

### DESCRIPTION

The engine cowling installation and firewall should be inspected and modified as specified in this Service Bulletin.

### COMPLIANCE

Optional: may be accomplished if desired.

**NOTE:** For airplane serial numbers 17281110 thru 17281216 and 172S9083 thru 172S9638: this Service Bulletin should be accomplished concurrently with SB08-53-02.

### APPROVAL

FAA approval has been obtained on technical data in this publication that affects airplane type design.

## MANPOWER

- A. Inspection for firewall cracks: 2.9 man-hours per airplane.  
If necessary, add 9.0 man-hours per repair doubler for fabrication and installation.  
If necessary, add 4.3 man-hours if repair doubler is installed behind the battery box.  
If necessary, add 70.0 man-hours if lower firewall replacement is required.
- B. Inspection of the engine cowling alignment and fit, installation of the engine cowling adjustable plates, and installation of nose cap reinforcement plates: 14.4 man-hours per airplane.  
If necessary, add 22.6 man-hours per airplane to replace the upper engine cowl.
- C. 1.8 man-hours per Service Station to fabricate one nose cap alignment tool.

## REFERENCES

Model 172 Series 1996 and On Maintenance Manual  
Single Engine Structural Repair Manual

**NOTE:** Make sure all publications used are complete and current.

**NOTE:** This information shall be considered an amendment to the Cessna Manufacturer's Service/Maintenance Manual.

## OTHER PUBLICATIONS AFFECTED

Model 172R & Model 172S Illustrated Parts Catalog

**NOTE:** Make sure all publications used are complete and current.

## MATERIAL PRICE AND AVAILABILITY

The parts below are available from Cessna Parts Distribution through an appropriate Cessna Service Station.

<u>Part Number</u>	<u>Description</u>	<u>Qty/Airplane</u>
<b>Parts For Cowling Alignment And Modification</b>		
AN525-10R10	Screw, Forward Cowl	8 (if necessary)
AN525-832R6	Screw, Adjust Plate	20
AN525-832R8	Screw, Adjust Plate	(as/if necessary)
J7444-42	Mount, Shock	(as necessary)
K000912	Kit, Primer	(as necessary)
MS20426AD3-2A	Rivet, Nose Cap and Seals	16
MS20426A3-4A	Rivet, Nose Cap Plate and Seals	46
MS21042L08	Nut, Adjust Plate	40
MS21059L3K	Nutplate, Nose Cap Plate	8
MS24693S48	Screw, Adjust Plate	20
MS24693S50	Screw, Adjust Plate	20
MS24694C52	Screw, Use with S3881-3 Washer	8

NAS1149FN232P	Washer, Baffle Seal	(as necessary)
P840306	Tape, Polyurethane	(approx 12 ft)
S1021Z8-8	Screw, Align Tool	4 / tool
S1438-41	Washer, Nylon	8 (if necessary)
S2319C4	Fastener, 1/4 Turn	(as necessary)
S2319C5	Fastener, 1/4 Turn	(as necessary)
S2319C6	Fastener, 1/4 Turn	(as necessary)
S2319C7	Fastener, 1/4 Turn	(as necessary)
S2319C8	Fastener, 1/4 Turn	(as necessary)
S2319C9	Fastener, 1/4 Turn	(as necessary)
S2319-65	Grommet, 1/4 Turn Fastener	(as necessary)
S2319-66	Grommet, 1/4 Turn Fastener	(as necessary)
S3806-9	.032 Alclad Aluminum (to make upper nose cap reinforcement plates)	(as necessary)
S3881-3	Washer, Countersunk	8
U074093	Marker, Alodine 1132	(as necessary)
0552212-245	Cowl Assembly, Upper	1 (if necessary)
0552227-1	Shim, Shock Mount	(if/as necessary)
0555250-17	Seal, Baffle	1
0555250-18	Seal, Baffle	1
0555250-19	Seal, Baffle	1
0555259-25	Seal, Baffle	1
0555259-26	Seal, Baffle	1
0555259-27	Seal, Baffle	1
0591009-2	Adjustment Plate, Shock Mount	20

#### **Parts For Firewall Repair**

0553031-3	Firewall Assembly, Lower	1 (if necessary)
MS21042-06	Nut, Firewall Repair	(if/as necessary)
MS21042-08	Nut, Firewall Repair	(if/as necessary)
MS35206-226	Screw, Firewall Repair	(if/as necessary)
MS35206-241	Screw, Firewall Repair	(if/as necessary)
U000117S	Sealant (200 Gram)	(if/as necessary)
MS20427M4-5	Rivet	(if/as necessary)
MS20427M5-5	Rivet	(if/as necessary)
MS20470AD4-4A	Rivet	(if/as necessary)
MS20615-4M4	Rivet	(if/as necessary)
MS20615-4M5	Rivet	(if/as necessary)

MS20615-5M4	Rivet	(if/as necessary)
MS20615-5M6	Rivet	(if/as necessary)

## CREDIT INFORMATION

### A. Airplanes In Warranty

#### Firewall Coverage:

A labor allowance credit of 2.9 man-hours per airplane will be provided to inspect the firewall for cracks.

If necessary, a labor allowance credit of 9.0 man-hours, applicable parts credit, and a miscellaneous parts credit of \$18.00 per repair doubler will be provided to fabricate and install the doubler.

If necessary, an additional labor allowance credit of 4.3 man-hours per repair doubler will be provided to install a repair doubler behind the battery box.

If necessary, a labor allowance credit of 70.0 man-hours, applicable parts credit, and a miscellaneous parts credit of \$ 12.00 per airplane will be provided to replace the lower firewall.

#### Cowling Installation Coverage:

A labor allowance credit of 14.4 man-hours per airplane will be provided for inspection of the engine cowling alignment and fit, installation of the engine cowling adjustable plates, and installation of nose cap reinforcement plates. Applicable parts credit will be provided.

If the existing upper cowl is retained, a miscellaneous parts credit of \$58.00 per airplane will be provided.

If necessary, a labor allowance credit of 22.6 man-hours per airplane will be provided to replace the upper cowl. Applicable upper cowl parts credit and a miscellaneous parts credit of \$58.00 per airplane will be provided.

### B. Airplanes Beyond Warranty

#### Firewall Coverage:

If necessary, applicable parts credit and a miscellaneous parts credit of \$18.00 will be provided per repair doubler to fabricate and install the doubler.

If necessary, applicable parts credit and a miscellaneous parts credit of \$12.00 will be provided per airplane to replace the lower firewall.

#### Cowling Installation Coverage:

If the existing upper cowl is retained, a miscellaneous parts credit of \$58.00 per airplane will be provided.

If upper cowling replacement is necessary, applicable upper cowl parts credit and a miscellaneous parts credit of \$58.00 per airplane will be provided.

### C. Nose Cap Alignment Fixture Tool Coverage

A labor allowance credit of 1.8 man-hours plus a miscellaneous parts credit of \$12.00 per Service Station will be provided to fabricate one nose cap alignment fixture.

To receive credit, the work must be completed and a Warranty Claim submitted by a Cessna Single Engine Service Station within 30 calendar days of Service Bulletin compliance before the credit expiration dates shown below.

**NOTE:** For airplanes that require replacement of the lower firewall assembly, the removed firewall shall be held for field scrap per standard procedures.

**NOTE:** For airplanes that require replacement of the upper cowl, the removed cowl shall be held for field scrap per standard procedures.

Domestic . . . . . January 28, 2009  
 International . . . . . January 28, 2009

**Special Note to Service Stations:**

When you complete the Warranty Claim, the labor allowance claimed shall be itemized for each above action completed.

**ACCOMPLISHMENT INSTRUCTIONS**

**Weight And Balance Information**

Negligible

**Material Information**

The parts listed below may be necessary.

<b>NEW P/N</b>	<b>QUANTITY</b>	<b>DESCRIPTION</b>	<b>OLD P/N</b>	<b>DISPOSITION</b>
AN525-10R10	8	Screw	None	
AN525-832R6	22	Screw	None	
AN528-832R8	As necessary	Screw	Same	Discard
J7444-42	As necessary	Shock Mount	Same	Discard
MS20426AD3-2A	16	Rivet	Staple	Discard
MS20426A3-4A	46	Rivet	None	
MS21042L08	40	Nut	None	
MS21059L3K	8	Nutplate	None	
MS24693S48	20	Screw	None	
MS24693S50	20	Screw	None	
MS24694C52	8	Screws	None	
MS21042L08	40	Nut	None	
MS21059L3K	8	Nutplate	None	
MS24693S48	20	Screw	None	
MS24693S50	20	Screw	None	
MS24694C52	8	Screws	None	
NAS1149FN232P	As necessary	Washer	None	
P840306	1	Polyurethane tape	None	
S1021Z8-8	As necessary	Screw	None	

S1438-41	8	Washer, Nylon	None	None
S2319C4	As necessary	Fastener-Cowl	S2319	Discard
S2319C5	As necessary	Fastener-Cowl	S2319	Discard
S2319C6	As necessary	Fastener-Cowl	S2319	Discard
S2319C7	As necessary	Fastener-Cowl	S2319	Discard
S2319C8	As necessary	Fastener-Cowl	S2319	Discard
S2319C9	As necessary	Fastener-Cowl	S2319	Discard
S2319-65	As necessary	Grommet	S2319-61	Discard
S2319-66	As necessary	Grommet	S2319-61	Discard
S3881-3	8	Washer	None	
0552212-245	1	Upper Cowl Assembly	0552212-45	
0552227-1	As necessary	Shim	None	
0555250-17	1	Seal	0555250-5	Discard
0555250-18	1	Seal	0555250-6	Discard
0555250-19	1	Seal	0555250-7	Discard
0555259-25	1	Seal	0555259-10	Discard
0555259-26	1	Seal	0555259-11	Discard
0555259-27	1	Seal	0555259-12	Discard
0591009-2	20	Shock Mount Adjustment Plate	None	

The parts listed below may be necessary for repair of the firewall:

<b>NEW P/N</b>	<b>QUANTITY</b>	<b>DESCRIPTION</b>	<b>OLD P/N</b>	<b>DISPOSITION</b>
MS20427M4-5 (Note 1)	As necessary (Approximately 20)	Rivet	Same	Discard
MS20427M5-5 (Note 1)	As necessary (Approximately 20)	Rivet	Same	Discard
MS20470AD4-4A	As necessary (Approximately 20)	Rivet	Same	Discard
MS20615-4M4 (Note 1)	As necessary (Approximately 20)	Rivet	Same	Discard
MS20615-4M5	As necessary (Approximately 20)	Rivet	Same	Discard
MS20615-5M4 (Note 1)	As necessary (Approximately 20)	Rivet	Same	Discard
MS21042-06	As necessary	Nut	None	
MS21042-08	As necessary	Nut	None	
MS35206-226	As necessary	Screw	None	
MS35206-241	As necessary	Screw	None	

0553031-3

1

Firewall, Lower  
Assembly

Same

Discard

Note 1: MS20427M4-5 and MS20615-4M4 Rivets are standard rivets to install the 0553031-3 Lower Firewall Assembly. If the rivet hole size is larger than 0.138-inch diameter, use MS20427M5-5 and MS20615-5M4 Rivets as necessary.

The materials or equivalent that follow may be necessary:

NAME	NUMBER	MANUFACTURER	USE
Corrosion Resistant Primer	K000912	Cessna Aircraft Company Cessna Parts Distribution 5800 East Pawnee PO Box 1521 Wichita, KS 67218	To apply to bare metal
Alodine 1132 Marker	U074093	Cessna Aircraft Company Cessna Parts Distribution 5800 East Pawnee PO Box 1521 Wichita, KS 67218	To apply to bare metal
CMNP009 Sealant	U000117S (200 gram)	Cessna Aircraft Company Cessna Parts Distribution 5800 East Pawnee PO Box 1521 Wichita, KS 67218	Sealant for the firewall
0.032-inch Alclad Aluminum	2024-T3 or S3806-9	Purchase locally or purchase from: Cessna Aircraft Company Cessna Parts Distribution 5800 East Pawnee PO Box 1521 Wichita, KS 67218	To make the nutplate reinforcement plates for the upper nose cap
0.016-inch Stainless Steel	301 annealed stainless steel per MIL-S-5059 or equivalent. Alternate material, 302 or 304 annealed stainless steel sheet per AMS5516 or equivalent	Purchase locally	To make firewall repair doubler
Plywood, 0.50-inch thickness (alternate is 0.375 inch)		Purchase locally	To make the nose cap alignment fixture
0.040-inch Aluminum	2024-T3	Purchase locally	To make the nose cap alignment fixture attach angles
Nylon Webbing, Rope, or Shock Cord		Purchase locally	To attach the nose cap alignment fixture to the propeller

## Instructions

1. Electrically ground the airplane and turn all switches to the "OFF" position. If external power is connected to the airplane, disconnect external power from receptacle.
2. Remove the upper engine cowling and disconnect the airplane battery. (Refer to the Model 172 Series 1996 and On Maintenance Manual, Chapter 24, Electrical Power.)
3. Attach maintenance warning tags to the battery and external power receptacle with the following instruction: **DO NOT CONNECT ELECTRICAL POWER - MAINTENANCE IN PROGRESS.**
4. Do the inspection steps below with the upper and lower cowling installed.

- A. Install the upper engine cowling.
- B. Look inside the oil door and the APU door and do an inspection for the condition of each shock mount.

**NOTE:** Table 1, Cowling Fit Dimensions is available for you to record measurements and analyze the total cowling to fuselage fit.

**NOTE:** If any of the three conditions in the list below are found, the cowling fit and alignment will require modification.

- (1) See if the shock mounts look bent over or out of alignment with the fastener studs.
- (2) See if the shock mounts appear to be under excessive stress.
- (3) See if the shock mounts look normal.

**NOTE:** Normal means the shock mount is under normal compressive load, has no unusual stress, and the shock mount is centered with the cowling cam lock hole.

- C. (Refer to Figure 1, Detail C and View A-A.) Measure the gap between the aft edge of the upper and lower cowlings, and the forward fuselage skin.

**NOTE:** The allowable gap is 0.03-inch to 0.25-inch, with 0.12-inch gap preferred. In the area within 5.0 inches above and 5.0 inches below the static port (left side only, the allowable gap is 0.06-inch to 0.13-inch with 0.10 inch preferred).

**NOTE:** All cowling fit measurements must be made with both the upper and lower cowlings installed with all S2319 Cowl Fasteners engaged in all eleven of the shock mounts.

- (1) Measure the gap between the inner surface of the cowling skin and the exterior surface of the forward fuselage skin adjacent to each S2319 Cowl Fastener.
- (2) (Refer to Figure 1, Detail C.) Give special attention to the right and left cowling corners on the upper cowling between the BL 13.40 and WL 7.10 S2319 Cowl Fastener locations, and on the lower cowling between the BL 13.48 and WL 13.25 S2319 Fastener locations.
- (3) Make a note about each shock mount location if the gap is not within specification.
  - (a) Write the measurements on masking tape and put next to each S2319 Cowl Fastener location as you do the inspection.
  - (b) Write the cowling fit inspection measurements in Table 1, Cowling Fit Dimensions.

TABLE 1. COWLING FIT DIMENSIONS	
SHOCK MOUNT POSITION	COWLING/FUSELAGE GAP (INCHES)
1	
2	
3	
4	
5	
6	
7	
8	
9	
10	
11	

5. Remove the upper cowling. (Refer to the Model 172 Series 1996 And On Maintenance Manual, Chapter 71, Cowling - Maintenance Practices.)

**NOTE:** The S2319 Cowl Fasteners should disengage from the shock mount receptacles easily. If the S2319 Cowl Fasteners are difficult to turn or if they bind or appear to be preloaded, it may be an indication that the cowling fit and alignment at that location needs adjustment.

6. Remove and keep all of the S2319 Cowl Fasteners from the aft edge of the upper cowling but do not remove the top center fastener.

**NOTE:** The top center fastener will be used to maintain the longitudinal position of the cowling in future steps.

7. Remove the lower cowling. (Refer to the Model 172 Series 1996 And On Maintenance Manual, Chapter 71, Cowling - Maintenance Practices.)

**NOTE:** Make note how easy the lower cowling S2319 Cowl Fasteners disengage from the shock mount receptacles. If the S2319 Cowl Fasteners are difficult to turn or if they bind or appear to be preloaded, it may be an indication that the cowling fit and alignment at that location needs adjustment.

8. Remove and keep the S2319 Cowl Fasteners from the aft edge of the lower cowling.

9. Do the inspection steps below.

- A. Look for areas where there is evidence of metal-to-metal contact between the cowling and the fuselage.

- B. Look for firewall cracks adjacent to the cowling shock mount brackets. If you do not find cracks, go to Step 10. If you find cracks, record all affected areas and repair the cracks as follows:

- (1) Remove and keep the Shock Mount Bracket to get access to the crack(s). (Refer to Model 172 Series 1996 And On Maintenance Manual, Chapter 71.)

- (2) Measure overall crack(s) length.

- (3) If any crack length is longer than 3.00 inches, remove the existing lower firewall assembly and replace it with a 0553031-3 Firewall Lower Assembly. Go to Step 9C. (Refer to Model 172 Series 1996 And On Maintenance Manual, Model 172R & Model 172S Illustrated Parts Catalog and the Single Engine Structural Repair Manual.)

**NOTE:** New 0553031-3 Firewall Lower Assemblies include 0553035-1 and 0553035-2 Gussets.

- (4) (Refer to Figure 4, View A-A.) If crack length is 3.00 inches or less:
- (a) Remove the pilot and copilot seats. (Refer to Model 172 Series 1996 And On Maintenance Manual, Chapter 25, Flight Compartment - Maintenance Practices.)
  - (b) Remove the pilot and/or copilot rudder pedal shields as necessary.
  - (c) Remove and keep carpeting and soundproofing material from the lower firewall as necessary to get access to lower firewall. (Refer to Model 172 Series 1996 And On Maintenance Manual, Chapter 25, Soundproofing and Insulation - Maintenance Practices.)

**CAUTION:** WHEN DRILLING HOLES, USE OF A DRILL STOP IS NECESSARY TO PREVENT DAMAGE TO OTHER COMPONENTS OR ASSEMBLIES LOCATED IN THE AREA.

- (d) Stop drill crack(s) using a Number 30 (0.128 inch diameter) drill bit.
- (e) (Refer to Figure 4, View A-A.) Fabricate a doubler similar to the one shown, ensuring allowance for minimum edge distance spacing of screws. Doubler material is to be 0.016 inch 301 Annealed Stainless Steel (per MIL-S-5059 or equivalent) with 0.030 inch minimum bend radius when necessary. Acceptable alternate doubler materials are 302, 304, or 321 Annealed Stainless Steel sheet per AMS5516 or equivalent.

**NOTE:** (Refer to Figure 4, Detail A.) The doubler may be installed on the aft side of the firewall in areas where the 0513109-90 Reinforcement is installed on forward side of firewall.

- (f) Remove rivets at locations common to the 0513109-90 Reinforcement. Cut edge of doubler to match edge of firewall sheet if necessary.
- NOTE:** Use of existing 0.128 inch diameter holes is preferred if within tolerance (0.128 inch diameter +0.008/-0.000) for use with MS35206-226 Screws. Oversize or out of tolerance holes require use of MS35206-241 Screws.
- (g) Find fastener locations and drill pilot holes in the doubler with a Number 40 (0.098 inch diameter) drill bit. Deburr the holes and clean debris.
  - (h) Match drill firewall from pilot holes in fabricated doubler starting with a Number 40 (0.098 inch diameter) drill, and graduate to a Number 28 (0.140-inch diameter) drill.
  - (i) Match drill doubler from existing holes in firewall starting with a Number 40 (0.098 inch diameter) drill, and graduate to a Number 28 (0.140-inch diameter) drill if existing holes meet previously noted diameter tolerance and are not dimpled or distorted.
  - (j) Holes that do not meet previously noted diameter tolerance or are dimpled or distorted, match drill doubler from existing holes in firewall with a Number 20 (0.161-inch diameter) drill.
  - (k) Deburr holes in firewall and doubler.
  - (l) (Refer to Figure 4, View A-A.) If the mid section of the crack is more than 0.62 inch from the closest screw, use of a secondary screw location will be necessary.

**NOTE:** Make sure that a minimum of 0.31-inch edge distance from edge of crack and minimum screw spacing of two times the edge distance is kept.

(m) Fay seal doubler with CMNP009 Sealant 0.50 inch wide around area, measured in all directions from the crack. (Refer to the Structural Repair Manual, Chapter Firewall Repair - Approved Repairs.)

(n) (Refer to Figure 4, View A-A.) Install the fabricated doubler to firewall assembly with MS35206-226 (MS35206-241 oversize) Screws and MS21042-06 (MS21042-08 oversize) Nuts as shown.

**NOTE:** Make sure a minimum of 0.31 inch edge distance from edge of crack and minimum screw spacing are kept.

(o) Install the removed shock mount bracket(s) with the kept attaching hardware. (Refer to Model 172 Series 1996 And On Maintenance Manual, Chapter 71.)

C. Look at the shock mounts to find if there is abnormal wear, compression, or cracks, and discard any shock mounts that are not serviceable. Record all affected areas.

D. (Refer to Figure 1, Detail A and Detail B.) Look for evidence of wear between the upper cowling stiffener and the metal part of the baffles. Record all affected areas.

E. Look at the air box filter housing fasteners and determine if they have rubbed on the lower forward baffles. Record all affected areas (Refer to the Model 172 Series 1996 And On Maintenance Manual, Chapter 71, Cowling - Maintenance Practices.)

10. Install the 0591009-2 Shock Mount Adjustment Plates.

**NOTE:** The 0591009-2 Shock Mount Adjustment Plates are designed to help with the alignment and the fit of the upper and lower engine cowls and the attachment to the J7444-42 Shock Mounts.

A. Remove the shock mounts from each shock mount bracket, but do not remove the center upper shock mount for the upper cowling.

**NOTE:** The top center fastener and shock mount will be used to help maintain the longitudinal position of the cowling in future steps.

B. (Refer to Figure 1, Detail C, Detail F, and Detail G.) Install new 0591009-2 Shock Mount Adjustment Plates on each of the shock mount brackets.

(1) Refer to the gap measurements you noted in Step 4C to consider the amount of gap there is at each shock mount location to install the shock mount and adjustable plates. Consider if one or two adjustable plates, and if additional 0552227-1 Shims are needed to provide the gap specification for each location.

(2) Install one new 0591009-2 Shock Mount Adjustment Plate with MS24693S50 Screws on each shock mount bracket as close to the center of each of the brackets as possible. The upper middle bracket will not get an adjustable plate at this time as the current shock mount must remain to provide longitudinal position of the cowling in future steps.

**NOTE:** (Refer to Figure 1, Detail F and Detail G.) Each shock mount bracket may need either one or two 0591009-2 Shock Mount Adjustment Plates to be installed to get good alignment between the cowling fastener and the shock mount as shown in the illustration.

**NOTE:** The two shock mount brackets next to the engine truss mount on each side may keep the 0591009-2 Shock Mount Adjustment Plates from an installation that is centered on the shock mount bracket. It may be necessary to remove some of the 0591009-2 Shock Mount Adjustment Plate material to keep the plates from contacting the engine truss and the firewall. These adjustment plates must be installed in a position that aligns the new shock mount to the cowling fastener.

- C. Put a 0.12-inch constant thickness spacer where the aft edge of the upper and lower cowlings, and the forward fuselage skin overlap.

**NOTE:** Examples of possible spacer material are rubber baffle, nylon webbing, velcro pile, or equivalent.

**NOTE:** The gap range in this location is 0.03-inch to 0.25-inch, with 0.12-inch preferred. For the area within 5.0 inches above and below the static port (left side only) the allowable gap is 0.06-inch to 0.13-inch with 0.10-inch preferred.

- D. Install the lower cowling and upper nose cap temporarily over the spacer material on the fuselage skin.

**NOTE:** Use temporary fasteners such as bungee cords to hold the aft lower cowling in place while the nose cap is adjusted for correct fit in the next step.

- (1) Use the upper cowling with the center shock mount and cowling fastener to longitudinally locate the lower cowling.
- (2) Use masking tape as necessary to help hold the longitudinal position of the lower cowling while Step 11 is accomplished.
- (3) Remove the upper cowling.

#### 11. Cowling and Shock Mount Alignment Procedure:

- A. (Refer to Figure 2, Detail A and Figure 3, Detail C.) Make a nose cap alignment fixture.

- (1) Use 0.50-inch thick plywood, particle-board or similar rigid material for the template that can be made with common woodworking tools.

**NOTE:** Use additional material as necessary to fill in the gap between the spinner bulkhead and nose cap.

- B. (Refer to Figure 2, Detail A.) Fabricate two attach angles from 2024-T3 Aluminum.

- C. (Refer to Figure 3, Detail A.) Position the propeller so that the blades are horizontal.

**NOTE:** Use a thin layer of felt, flannel or similar soft material between the alignment fixture and the nose cap to protect the nose cap paint.

- (1) (Refer to Figure 3, Detail A and Detail C.) Install the nose cap alignment fixture between the propeller spinner aft bulkhead and the spinner boss on the nose cap assembly.

**NOTE:** (Refer to Figure 2, Detail A.) The six small holes in the fixture are positioned for clearance of the rivet butts that protrude through the spinner aft bulkhead so the fixture will fit flat against the bulkhead.

- (a) Make sure that the tabs on either side of the fixture are centered behind the propeller blades.

**NOTE:** The alignment fixture must be concentric with the aft spinner bulkhead. The top edge of the center cutout in the alignment fixture must contact the top surface of the propeller spacer to center the fixture vertically on the propeller spacer.

- (2) (Refer to Figure 3, Detail B.) Install one attach angle to the nose cap assembly on the inboard face of each of the (left and right hand) cooling air inlet openings. Use the AN528-832R8 Screw installed in the nose cap forward location and install it through the slotted hole in the flange of the attach angle.

- (3) (Refer to Figure 3, Detail C.) Move the nose cap assembly to center the nose cap spinner boss on the propeller spacer.

- (a) Install the attach angles to the alignment fixture with four S1021Z8-8 Screws, or equivalent.

- (4) Adjust the spinner aft bulkhead to nose cap distance if it is not within the 0.50 inch to 0.60 inch range.
  - (a) (Refer to Figure 3, Detail D.) Hold the alignment fixture to the propeller spinner aft bulkhead with a shock cord, rope, nylon webbing or similar material.
    - 1 Put the cord material through one of the holes in one end of the alignment fixture, around propeller blade, and back through the other hole in alignment fixture.
    - 2 Put the cord material through one of the nose cap inlets, across the top of the propeller spacer (aft of the nose cap), then out the nose cap Inlet on the opposite side, through one of the holes in one end of the alignment fixture around the propeller, and back through the alignment fixture holes.
    - 3 Put the cord back through the nose cap inlets and under the propeller spacer
    - 4 Tighten the nose cap assembly against the alignment fixture with the cord material.
    - 5 Pull the ends of the cord material tight and tie a knot in front of one of the prop blades.

**NOTE:** You can apply additional tension as necessary to hold the nose cap, template, and aft spinner surfaces flush against one another.

12. Temporarily install the upper cowling.
  - A. Connect the center cowling fastener to the center shock mount to provide longitudinal reference for the shock mount location/installation procedure.
  - B. Connect the upper cowling to the lower cowling on each side with the S2319 Cowl Fasteners.
  - C. Make sure the spacer material is in place between the cowling and the fuselage skin before the new location for each shock mount is center punched.
13. Transfer the cowling fastener hole locations from the upper and lower cowlings to the 0591009-2 Shock Mount Adjustment Plates.
  - A. Use an S2319-65 Grommet or similar part as a guide and put a center punch through each S2319 Cowl Fastener hole in the cowlings and make a mark on each new 0591009-2 Shock Mount Adjustment Plate to identify where the center of the shock mount must be installed.
14. Remove the cowling nose cap alignment template fixture from the propeller and nose cap.
15. Remove the cowling after the new 0591009-2 Shock Mount Adjustment Plates are center punched.

**NOTE:** (Refer to Figure 1, Detail C.) Use the firewall bracket position location numbers shown and stamp the number of each shock mount respectively on the adjustment plate.

16. (Refer to Figure 1, Detail F.) Install the shock mounts.

**NOTE:** Make sure to use only serviceable shock mounts.

- A. Remove the 0591009-2 Shock Mount Adjustment Plates from the airplane and drill a 0.688-inch hole through the plate where they were marked in Step 13A.
- B. Use ten new 0591009-2 Shock Mount Adjustment Plates and center a shock mount on each one and mark the two screw mount holes and the center of the shock mount as shown.

**NOTE:** (Refer to Figure 1, Detail G.) 0591009-2 Shock Mount Adjustment Plates 1, 4, 8, and 11 located near the engine truss, may have the shock mounts mounted horizontally for clearance from the engine truss.

- C. Drill two Number 20 (0.161-inch diameter) holes in the 0591009-2 Shock Mount Adjustment Plate and one 0.688 inch hole in the center of the plate, directly under the center of the shock mount as shown. Deburr the holes.

**NOTE:** Make sure there is a minimum of 0.344 inch edge margin of material for the 0591009-2 Shock Mount Adjustment Plates.

**NOTE:** You will need to install either one or two 0591009-2 Shock Mount Adjustment Plates at each cowling fastener location, depending on the space available and the lateral adjustment necessary to get good shock mount to fastener alignment.

**NOTE:** At some shock mount locations, 0552227-1 Shims must be used to get the necessary gap between the cowl skin and the forward fuselage skin. (See Step 16K.)

- D. Countersink for the two Number 20 (0.161-inch diameter) holes 100°.
- E. Install the ten shock mounts on the ten 0591009-2 Shock Mount Adjustment Plates with two MS24693S48 Screws and two MS21042L08 Nuts.

**NOTE:** If shims are necessary to get proper spacing of the cowling, longer screws will be necessary.
- F. Use the 0591009-2 Shock Mount Adjustment Plates that were fitted to the airplane and the 0591009-2 Shock Mount Adjustment Plates with the shock mounts installed and align the 0.688 inch center holes.
- G. (Refer to Figure 1, Detail F.) With the two center holes aligned from both 0591009-2 Shock Mount Adjustment Plates, drill two 0.172 inch holes as shown. Make sure to center the holes as necessary to maintain a minimum edge distance of 0.344 inch.
- H. (Refer to Figure 1, Detail C.) Make sure to mark the location of each 0591009-2 Shock Mount Adjustment Plate.
- I. (Refer to Figure 1, Detail C.) Remove material from the adjustable plates as necessary to give clearance from the engine cowling, engine mount truss, and the firewall. Make sure that the cowling channel does not touch the edges of the adjustment plate at locations 1, 2, 5, 7, 10, and 11.
- J. Deburr holes. Apply Alodine and corrosion resistant primer as necessary.
- K. Install the 0591009-2 Shock Mount Adjustment Plates marked in Step 13A on the airplane with two MS24693S50 Screws.
  - (1) Make sure necessary clearance between 0591009-2 Shock Mount Adjustment Plate screws and cowling channels is kept.
  - (2) Remove material from the 0591009-2 Shock Mount Adjustment Plates as necessary to give clearance from the cowling channel, the engine mount truss, the firewall, and the external power receptacle.
- L. Install the 0591009-2 Shock Mount Adjustment Plates with the shock mounts installed as marked to the 0591009-2 Shock Mount Adjustment Plates installed on the airplane with two AN525-832R6 Screws and two MS21042L08 Nuts.

- 17. Install all S2319 Fasteners in the cowlings.

- 18. Remove the temporary spacer material from between the aft cowling skin and forward fuselage skin.

- 19. Install P840306 Polyurethane Tape to the cowlings.

- A. Clean and degrease the inner surface of cowling skins between 0552212 Inner Reinforcement Channel and aft edge of cowling skin. (Refer to Model 172 Series 1996 And On Maintenance Manual, Chapter 12-22-00.)

- B. Install P840306 Polyurethane Tape, or equivalent, on the inner surface of the upper and lower cowling skin between the inner reinforcement channel and aft edge of skin.

**NOTE:** Tape is necessary where metal-to-metal contact between the cowling skin and forward fuselage skin exists.

- C. Trim the tape flush with aft edge of skin if excess tape is present.

- D. Press the tape firmly in place to make adequate contact with the cowling skin and for a strong adhesive bond.

**NOTE:** The tape must stay in place to prevent possible fretting of skins.

- 20. Install the cowlings. (Refer to the 172 Series 1996 And On Maintenance Manual, Chapter 71, Cowlings - Maintenance Practices.)

- 21. Do a post modification inspection on the fit and clearance between the upper and lower cowlings and the fuselage skin.

**NOTE:** Make sure necessary gap clearance between the forward nose cowling and prop spinner is kept.

**NOTE:** Table 1, Cowling Fit Analysis, is available for you to record measurements again, and to analyze the total cowling to fuselage fit.

- A. (Refer to Figure 1, Detail C and View A-A.) Do a measurement of the gap between the aft edge of the upper and lower cowlings, and the forward fuselage skin.

**NOTE:** The allowable gap is 0.03 inch to 0.25 inch, with 0.12 inch preferred. In the area within 5.0 inches above and 5.0 inches below the static port (left side only), the allowable gap is 0.06 inch to 0.13 inch with 0.10 inch preferred.

**NOTE:** All cowling fit measurements must be made with both the upper and lower cowlings installed with all S2319 Cowl Fasteners engaged in all eleven of the shock mounts.

- (1) Measure the gap between the inner surface of the cowling skin and the exterior surface of the forward fuselage skin adjacent to each S2319 Cowl Fastener.
- (2) (Refer to Figure 1, Detail C.) Give special attention to the right and left cowling corners on the upper cowling between BL 13.40 and WL 7.10 1/4 turn fastener locations, and on the lower cowling between BL 13.48 and WL 13.25 1/4 turn fastener locations.
- (3) Do a visual inspection for necessary clearance of all shock mounts, brackets, and shock mount adjustment plates.
- (4) Identify each location where the gap is not within specification.
- (5) Remove the upper and lower cowlings.
- (6) Remove the shock mount plates that are out of tolerance and install 0552227-1 Shims as necessary to get the necessary gap.

**NOTE:** The shims are installed between the J7444 Shock Mounts and adjustable plates.

- (7) Install the upper and lower cowlings and do Steps 21A through 21A(6) again until there is necessary clearance.
- 22. (Refer to Figure 1, Detail A.) Do a visual inspection of the upper engine cowl to look for signs of wear on the forward S2319 Cowl Fasteners, for signs that the forward S2319 Cowl Fasteners are going to pull through or have pulled through the upper engine cowl, and for wear on the forward doubler on the bottom side of the upper engine cowl.
    - A. If one or more of the forward S2319 Cowl Fasteners are worn or have pulled through the upper engine cowl and the S2319-61 Grommet hole is larger than 0.70 inch, if a repair doubler has been installed, or if the forward doubler on the bottom side of the upper engine cowl is worn through and into the upper engine cowl skin, you must remove and discard the upper cowl and install a new 0552212-245 (with excess material) Upper Cowl Assembly. Go to Step 23.
    - B. If the forward S2319 Cowl Fasteners are not worn or pulled through the upper engine cowl and the S2319-61 Grommet hole is 0.70 inch or smaller, and if the forward doubler on the underside of the upper engine cowl is not worn through and into the upper engine cowl skin, go to Step 24.
  - 23. (Refer to Figure 1.) Install a new 0552212-245 Upper Engine Cowl as follows:
    - A. Install the nose cap alignment fixture made in Step 11.

- B. With the original upper engine cowl installed, trace around the four outer edges of the upper cowl onto the airplane.
- NOTE:** Use a grease pencil or equivalent to trace around the upper cowl on the airplane, so that the mark can be removed once the work has been completed.
- C. Remove the upper cowl.
- D. Locate and mark the center of the upper nose-cap and the upper edge of the airplane fuselage above the engine firewall.
- E. Locate and mark the center of the forward and the aft edge of the new 0552212-245 Upper Engine Cowl.
- F. Put a 0.12-inch constant thickness spacer where the aft edge of the upper cowl overlaps the forward fuselage skin along the firewall.
- NOTE:** Examples of possible spacer material are rubber baffle, nylon webbing, Velcro pile, or equivalent.
- G. Locate holes and install S2319-65 or S2319-66 Grommets (use S2319-65 or S2319-66 Grommets as necessary) and S2319 Cowl Fasteners on the aft edge of the 0552212-245 Upper Engine Cowl.
- (1) Temporarily install the new upper cowl and align the center marks of the cowl with the center marks made on the upper nose-cap and the upper edge of the firewall on the fuselage. Make sure that the cowl shock mounts are positioned within the cowl stiffener channel on the aft edge of the cowl.
  - (2) Trace and mark the aft edge of the upper cowl on the airplane fuselage, above the engine firewall.
  - (3) Remove the upper cowl and measure the distance between the new trace mark made in the step above, and the trace mark made from the original upper cowl.
  - (4) With the measurements taken from the step above, trim the new 0552212-245 Upper Engine Cowl to match the original cowl trace marks.
  - (5) Temporarily install the new upper cowl and check the fit with the trace mark made from the original upper cowl. Do Steps 23G(1) through 23G(4), until the aft edge of the new upper cowl is aligned with the original upper cowl marks.
  - (6) Locate the aft upper center J7444-42 Shock Mount above the engine firewall and make a mark of the location on the new 0552212-245 Upper Engine Cowl.
  - (7) With a Number 30 size drill and a drill stop, drill a pilot hole into the upper cowl where the mark was made in the step above.
  - (8) Check the alignment of the Number 30 pilot hole with the center of the J7444-42 Shock Mount and adjust the hole as necessary.
  - (9) (Refer to Figure 1, Detail D.) Remove the upper cowl and drill a 0.475-inch hole where the Number 30 size hole was drilled in the step above. Deburr and Alodine the hole.
  - (10) Temporarily install one S2319-65 or S2319-66 Grommet and one S2319 Cowl Fastener (use from S2319C4 to S2319C9 length cowl fasteners as necessary to get the correct length) in the hole drilled in the step above and install the upper cowl on the airplane. Always use the shortest S2319 Cowl Fastener that you can.
  - (11) Keeping the center marks of the new upper cowl with the upper nose-cap and the firewall marks, locate and make a mark of the two left and the two right J7444-42 Shock Mount center holes.
  - (12) With a Number 30 size drill and drill stop, drill four pilot holes centered on the J7444-42 Shock Mounts marked in the step above.
  - (13) Do a check of the alignment of the Number 30 size pilot holes with the center of each J7444-42 Shock Mount and adjust the hole locations as necessary.

- (14) Remove the upper cowl and drill four 0.475-inch holes where the pilot holes were drilled in the step above. Deburr and Alodine the holes.
  - (15) Temporarily install the new upper cowl with S2319-65 or S2319-66 Grommets and S2319 Cowl Fasteners (use from S2319C4 to S2319C9 length cowl fasteners as necessary to get the correct length). Always use the shortest S2319 Cowl Fastener that you can.
  - (16) With the new upper cowl installed, inspect the five J7444-42 Shock Mounts for forward, aft, and side-to-side stress.
    - (a) Adjust or replace the 0591009-2 Shock Mount Adjustment Plates as necessary to make sure that there is no stress on the shock mounts.
  - (17) Install the new S2319-65 or S2319-66 Grommets and S2319 Cowl Fasteners (use from S2319C4 to S2319C9 length cowl fasteners as necessary to get the correct length). Always use the shortest S2319 Cowl Fastener that you can.
- H. Locate holes and install S2319-65 or S2319-66 Grommets and S2319 Cowl Fasteners on the left and the right side lower edges of the 0552212-245 Upper Engine Cowl (use from S2319C4 to S2319C9 length studs as necessary to get the correct length) as necessary. Always use the shortest S2319 Cowl Fastener that you can.
- (1) Locate the five left receptacle holes for the S2319-65 or S2319-66 Grommets in the lower cowl. Mark and drill five Number 30 pilot holes in the upper cowl.
  - (2) Make sure the Number 30 size pilot holes are aligned with the center of each receptacle hole in the lower cowl and adjust the hole locations as necessary.
  - (3) Remove the upper cowl.
  - (4) Drill five 0.475-inch diameter holes where the Number 30 size holes were drilled in the step above. Deburr and Alodine the holes.
  - (5) Install new S2319-65 or S2319-66 Grommets and S2319 Cowl Fasteners (use from S2319C4 to S2319C9 length studs as necessary to get the correct length) as necessary. Always use the shortest S2319 Cowl Fastener that you can.
  - (6) Do Steps 23H(1) thru 23H(5) again for the right receptacle holes for the S2319-65 or S2319-66 Grommets.
- I. Put the 0552212-245 Upper Engine Cowl in position.
- (1) Temporarily install the upper cowl.
  - (2) Trace marks for the left and right lower edges of the upper cowl.
  - (3) Remove the upper cowl and measure the distance between the new trace mark made in the step above, and the trace mark made from the original upper cowl.
  - (4) Use the measurements taken from the step above, and trim the new upper cowl to match the original upper cowl trace marks.
  - (5) Deburr and Alodine the engine cowl edges as necessary.
  - (6) Remove and discard the eight S2319-50 Receptacles in the upper nose-cap.
  - (7) (Airplanes 17281110 thru 17281216 and 172S9083 thru 172S9638) Do SB08-53-02 now, before you continue with this Service Bulletin.
  - (8) Remove the spacer material from under the aft edge of the engine cowl.

- (9) Install the new upper cowl and measure the gap between where the aft edge of the upper cowl and the forward fuselage skin overlap. If gap is not correct, install 0552227-1 Shims under the J7444-42 Shock Mounts as necessary to get the correct gap.

**NOTE:** The gap range should be 0.03-inch to 0.25-inch, with 0.12-inch preferred. For the area within 5.0 inches above and below the static port (left side only), the allowable gap is 0.06-inch to 0.13-inch with 0.10-inch preferred.

**NOTE:** The forward end of the new 0552212-245 Upper Engine Cowling will not have new S2319 Fasteners installed.

- (10) Remove the upper cowl.
- (11) (Refer to Figure 1, Detail E.) Use 2024-T3 Aluminum that is 0.032-inch thick and make eight reinforcement plates that are each 1.70 inches wide and 1.00 inch long.
- (12) Make a mark for and drill a 0.25-inch diameter hole in the center of each of the reinforcement plates. Deburr the holes.
- (13) Center the holes drilled in the new reinforcement plates with the center of the holes for the S2319-50 Receptacles in the upper nose-cap, and match drill two Number 30 (0.128 inch diameter) holes where the rivets were installed that attached the S2319-50 Receptacles to the upper nose cap. Deburr the holes.
- (14) Temporarily install the eight reinforcement plates on the bottom of the upper nose-cap.
- (15) Temporarily install the new upper engine cowl.
- (16) With a Number 10 drill bit, match drill the holes from the eight reinforcement plates to the new upper engine cowl.
- (17) Deburr and apply Alodine to the holes as necessary.
- (18) Remove the new upper engine cowl.
- (19) Remove the eight reinforcement plates from the upper nose cap.
- (20) Drill two Number 40 (0.098-inch diameter) holes through each of the eight new reinforcement plates for the MS21059L3K Nutplates. Countersink the two holes with a 100 degree countersink. Deburr the holes and Alodine the reinforcement plates.
- (21) (Refer to Figure 1, Detail D.) Install the eight new MS21059L3K Nutplates to the new reinforcement plates that are attached to the upper nose-cap with the 16 MS20426AD3-2 Rivets.
- (22) Install the eight reinforcement plates on the bottom of the upper nose-cap with 16 MS20426A3-4 Rivets.
- (23) Temporarily install the new upper engine cowl.
- (24) Make marks to show the location of the forward edge of the new upper engine cowl.
- (25) Remove the new upper engine cowl.
- (26) Measure the distance between the marks made to show the forward edge of the new upper engine cowl and the marks made to show the forward edge of the old upper engine cowl. Record this measurement.
- (27) Use the measurement that you recorded and cut away the necessary amount of material to make the new upper engine cowl and the old upper engine cowl the same dimension. Deburr, Alodine, and roll the forward edge down so that when the cowl is installed, there are no gaps between the upper cowl and the upper nose-cap.

J. Remove the fixture tool.

K. Install new P840306 Polyurethane Tape where the new engine cowl makes contact with the nose-cap, lower engine cowl, and the aft edge of the cowl above the firewall.

- L. Install the new upper engine cowl and install the forward edge with eight AN525-10R10 Screws and eight S1438-41 Nylon Washers.
  - M. Go to Step 25.
24. Replace the fasteners that attach the upper engine cowl to the upper nose-cap as follows:
- A. Remove the upper cowl.
  - B. Remove and discard the eight S2319-50 Receptacles in the upper nose-cap.
  - C. (Airplanes 17281110 thru 17281216 and 172S9083 thru 172S9638) Do SB08-53-02 now, before you continue with this Service Bulletin.
  - D. (Refer to Figure 1, Detail E.) Use 2024-T3 Aluminum that is 0.032 inch thick and make eight reinforcement plates that are each 1.70 inches wide and 1.00 inch long.
  - E. Make a mark for and drill a 0.25-inch diameter hole in the center of each of the reinforcement plates. Deburr the holes.
  - F. Center the holes drilled in the new reinforcement plates with the center of the holes for the S2319-50 Receptacles in the upper nose-cap, and match drill two Number 30 (0.128 inch diameter) holes where the rivets were installed that attached the S2319-50 Receptacles to the upper nose cap. Deburr the holes.
  - G. Drill two Number 40 (0.098-inch diameter) holes through each of the eight new reinforcement plates for the MS21059L3K Nutplates. Countersink the two holes with a 100 degree countersink. Deburr the holes and Alodine the reinforcement plates.
  - H. (Refer to Figure 1, Detail D.) Install the eight new MS21059L3K Nutplates to the eight new reinforcement plates with the 16 MS20426AD3-2 Rivets.
  - I. Install the eight reinforcement plates on the bottom of the upper nose-cap with 16 MS20426A3-4 Rivets.
  - J. (Refer to Figure 1, Detail D.) Install the upper engine cowl with the S2319 Cowl Fasteners on the aft, left, and right sides of the engine cowl and eight new MS24694C52 Screws and S3881-3 Washers.
25. Do the steps below in addition to the steps that you have already done to better adjust the fit of the cowling.
- A. (Refer to Figure 1, Detail A and B.) Make necessary clearance adjustments between the 0552170 Upper cowling Stiffeners and the engine baffles.
    - (1) Trim the upper engine baffles up to 0.25 inches for clearance between the 0552170 Upper cowling Stiffeners and the baffles where metal-to-metal contact is found between them.
  - B. (Refer to Figure 1, Detail B.) Replace the seals on the forward right hand baffle assembly with new seals. (Refer to the Model 172R/172S Illustrated Parts Catalog, Chapter 71, Engine Baffles Installation.)
 

**NOTE:** The new seals are thinner and more flexible.

    - (1) Remove the staple fasteners and remove and discard the 0555250-5, 0555250-6, 0555250-7 Seals from the 0555250 Forward Right Hand Baffle Assembly. (Refer to the Model 172R/172S Illustrated Parts Catalog, Chapter 71, Engine Baffles Installation.)
    - (2) (Refer to Figure 1, Detail B.) Install new 0555250-17, 0555250-18, 0555250-19 Seals to the 0555250 Forward Right Hand Baffle Assembly with MS20426A3-4 Rivets and NAS1149FN232P Washers.
      - (a) Install one rivet at each staple location on the baffle assembly.
 

**NOTE:** Use only one of the two staple holes from each staple location on the baffle and install one rivet at each staple location.
- 1 Install the new seals in the same position and side of the baffle as the removed seals.
- 2 Drill one Number 40 (0.098 inch diameter) hole at each staple location on the baffles and through the new seal material.

- 3 Install each MS20426A3-4 Rivet so the rivet head is on the metal side of the baffle assembly and the NAS1149FN232P Washer is installed on the seal side of the baffle and attached by the butt of the rivet.

C. (Refer to Figure 1, Detail B.) Replace the seals on the forward left hand baffle assembly with new seals. (Refer to the Model 172R/172S Illustrated Parts Catalog, Chapter 71, Engine Baffles Installation.)

- (1) Remove the staple fasteners from the 0555259-10, 0555259-11, 0555259-12 Seals on the 0555259 Forward Left Hand Baffle Assembly. (Refer to the Model 172R/172S Illustrated Parts Catalog, Chapter 71, Engine Baffles Installation.)

- (2) (Refer to Figure 1, Detail B.) Install new 0555259-25, 0555259-26, 0555259-27 Seals to the 0555259 Forward Left Hand Baffle Assembly with MS20426A3-4 Rivets and NAS1149FN232P washers.

- (a) Install one rivet at each staple location on the baffle assembly.

**NOTE:** Use only one of the two staple holes from each staple position and install one rivet in the location.

- 1 Install the new seals in the same position and side of the baffle as the removed seals.

- 2 Drill one Number 40 (0.098 inch diameter) hole at each staple location on the baffles and through the new seal material.

- 3 Install each MS20426A3-4 Rivet so the rivet head is on the metal side of the baffle assembly and the NAS1149FN232P Washer is installed on the seal side of the baffle and attached by the butt of the rivet.

26. (Refer to Figure 1, Detail A.) Examine the aft end of the 0552212-23 and the 0552212-24 Stiffener on the upper right and upper left sides of the lower cowling, and examine the firewall flange and forward fuselage skin for signs that they have worn against the 0552212 Stiffener.

A. Trim the aft end of the 0552212-23 and 0552212-24 Stiffener at a 45° angle as necessary if the stiffener has worn against the firewall flange or forward fuselage skin.

**NOTE:** Trim the minimum amount of material from the stiffeners for sufficient clearance.

27. Eliminate metal-to-metal contact between the air filter housing and the lower forward baffle assemblies.

A. Hand shape the 0555250 and 0555259 Lower Forward Baffle Assemblies as needed to achieve clearance so the metal edges of the baffles do not touch the air filter housing assembly when the cowling is installed on the airplane.

28. Restore corrosion protection to portions of the cowling, firewall or fuselage as necessary.

29. Install the upper and lower cowling on the airplane and make sure the fit of the cowling fasteners align to the shock mounts. Do additional adjustments as necessary. (Refer to the Model 172 Series 1996 And On Maintenance Manual, Chapter 71, Cowling - Maintenance Practices.)

30. Paint the cowlings and fasteners as necessary.

31. Remove maintenance warning tags from battery and external power receptacle and connect battery.

32. Make an entry in the airplane logbook that states compliance and method of compliance with this Service Bulletin.

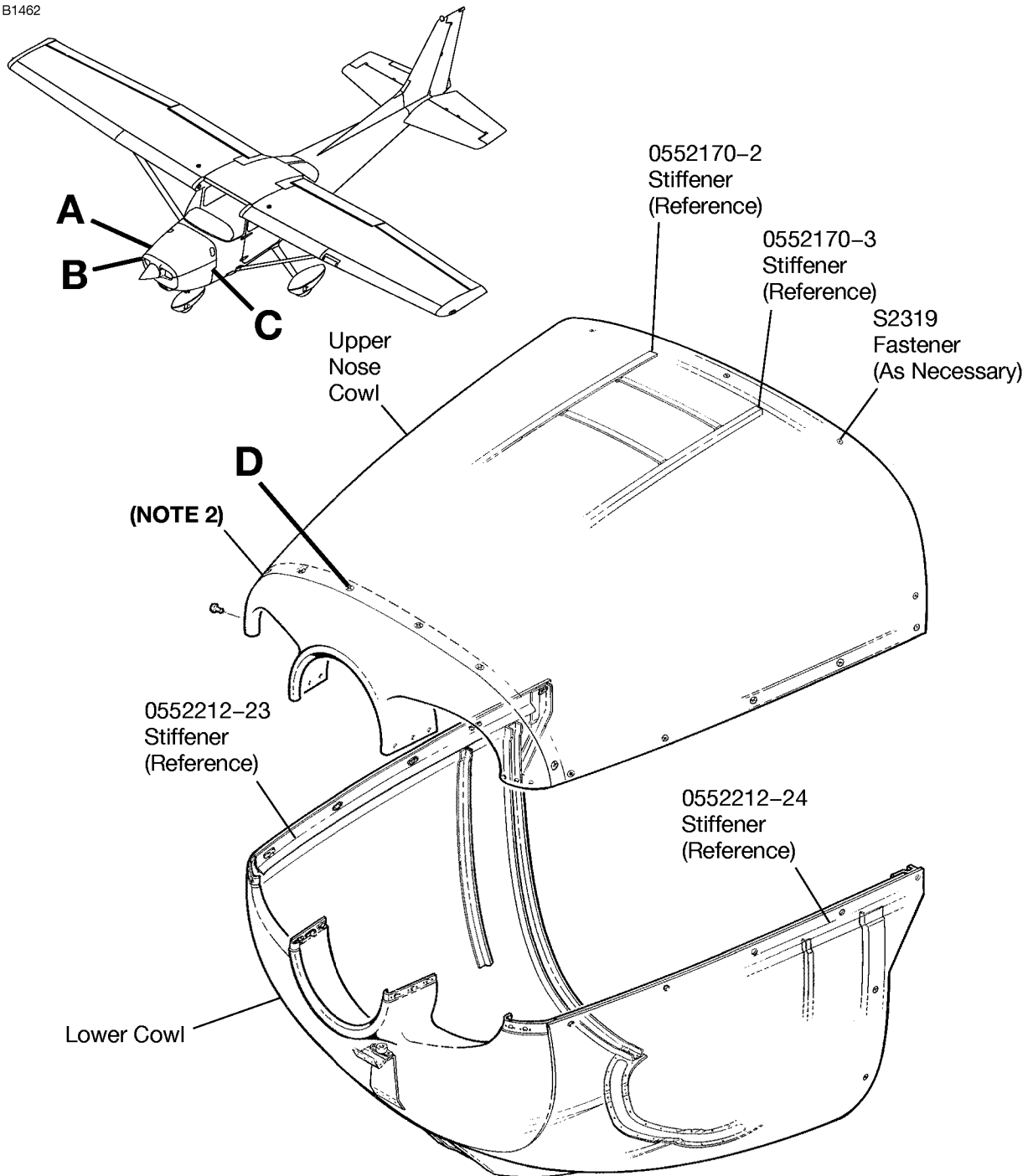

**NOTE 1:** All dimensions shown are in inches.

**NOTE 2:** Do a visual inspection of this area. Look for S2319-61 Grommets and S2319 Cowl Fasteners that are pulled through. Also look on the doubler on the bottom side of the cowl for wear that has gone through the doubler and into the cowl.

**DETAIL A**

Figure 1. Cowling Alignment Fit and Clearance (Sheet 1)

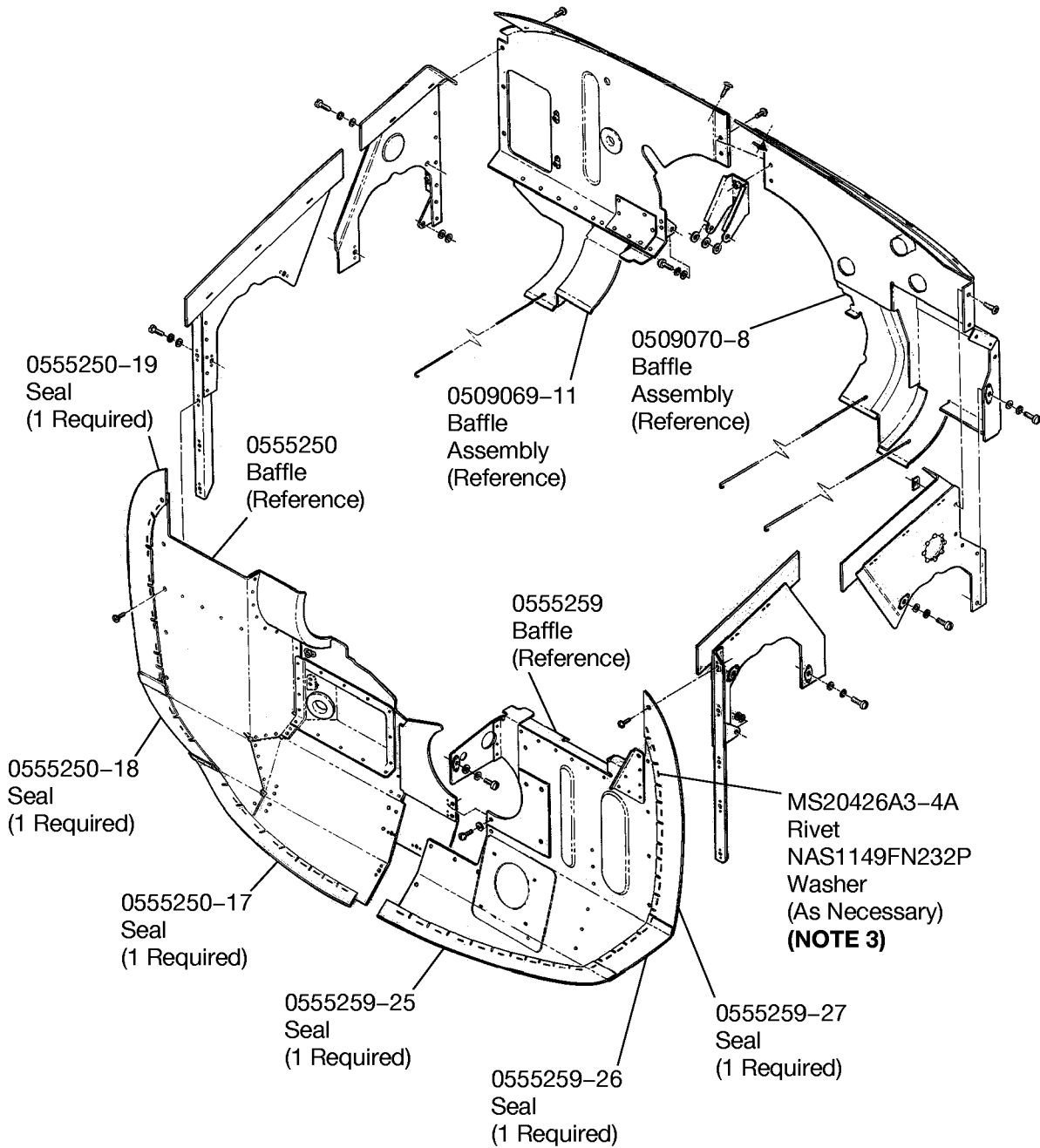

### DETAIL B

**NOTE 3:** New seal installation.

B05502001

Figure 1. Cowling Alignment Fit and Clearance (Sheet 2)

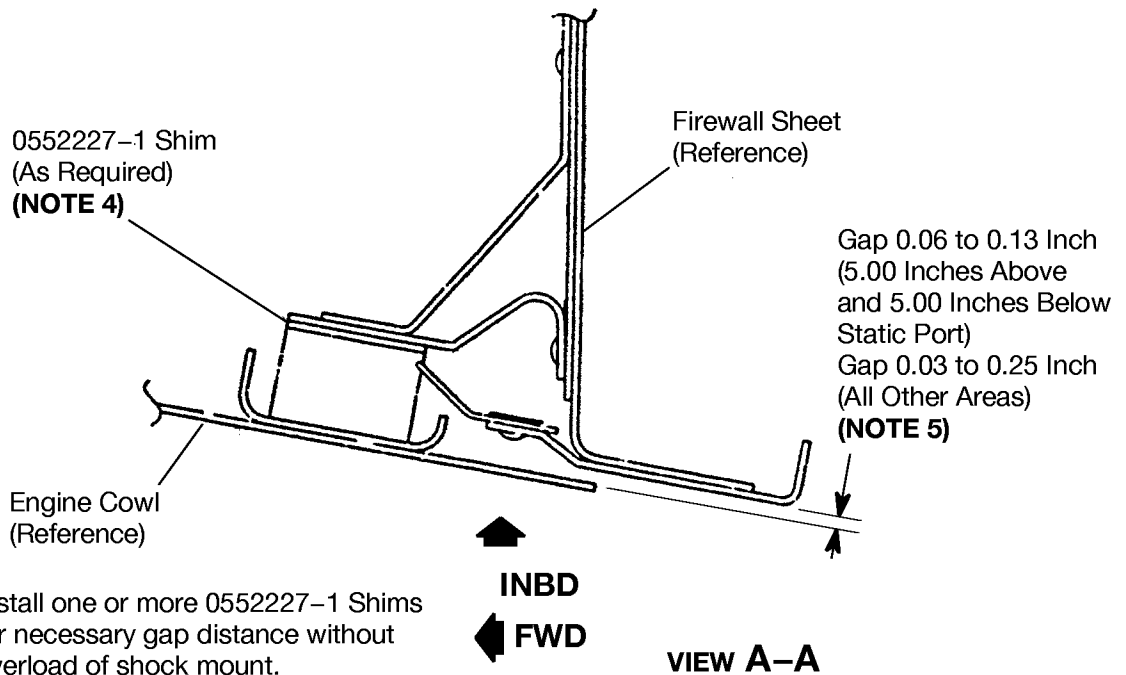
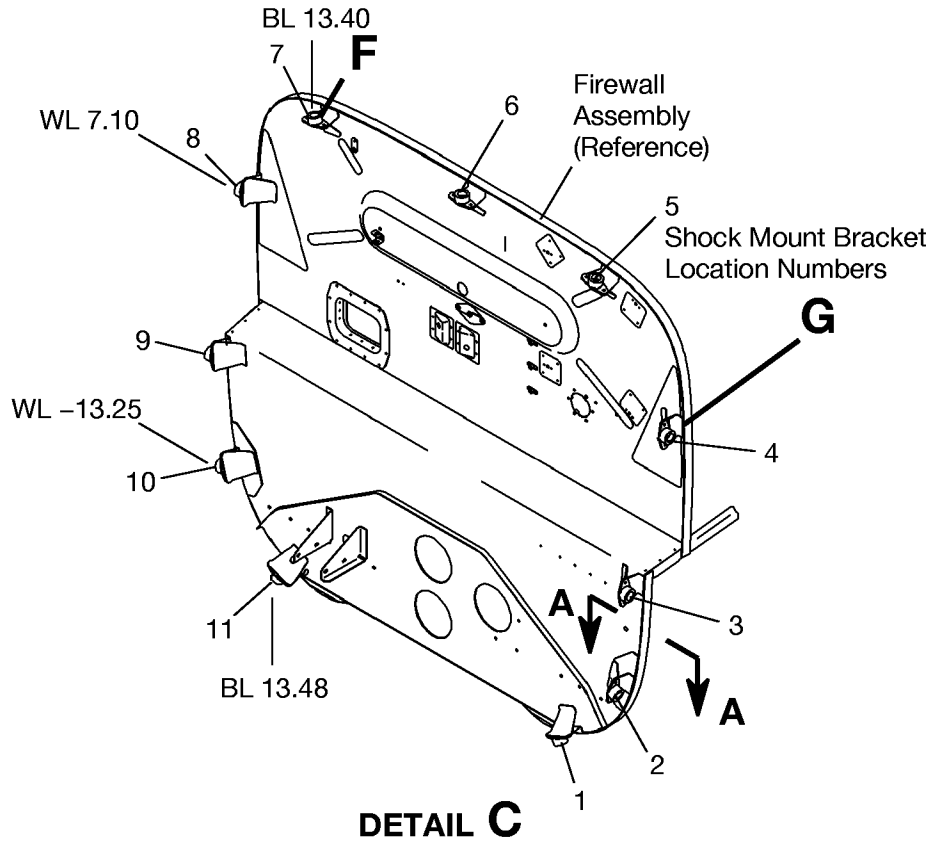

**NOTE 4:** Install one or more 0552227-1 Shims for necessary gap distance without overload of shock mount.

**NOTE 5:** Measure gap between nearest cowling fuselage skin or fastener.

Typical Lower Cowl Mount Without Adjustable Plates Shown

Figure 1. Cowling Alignment Fit and Clearance (Sheet 3)

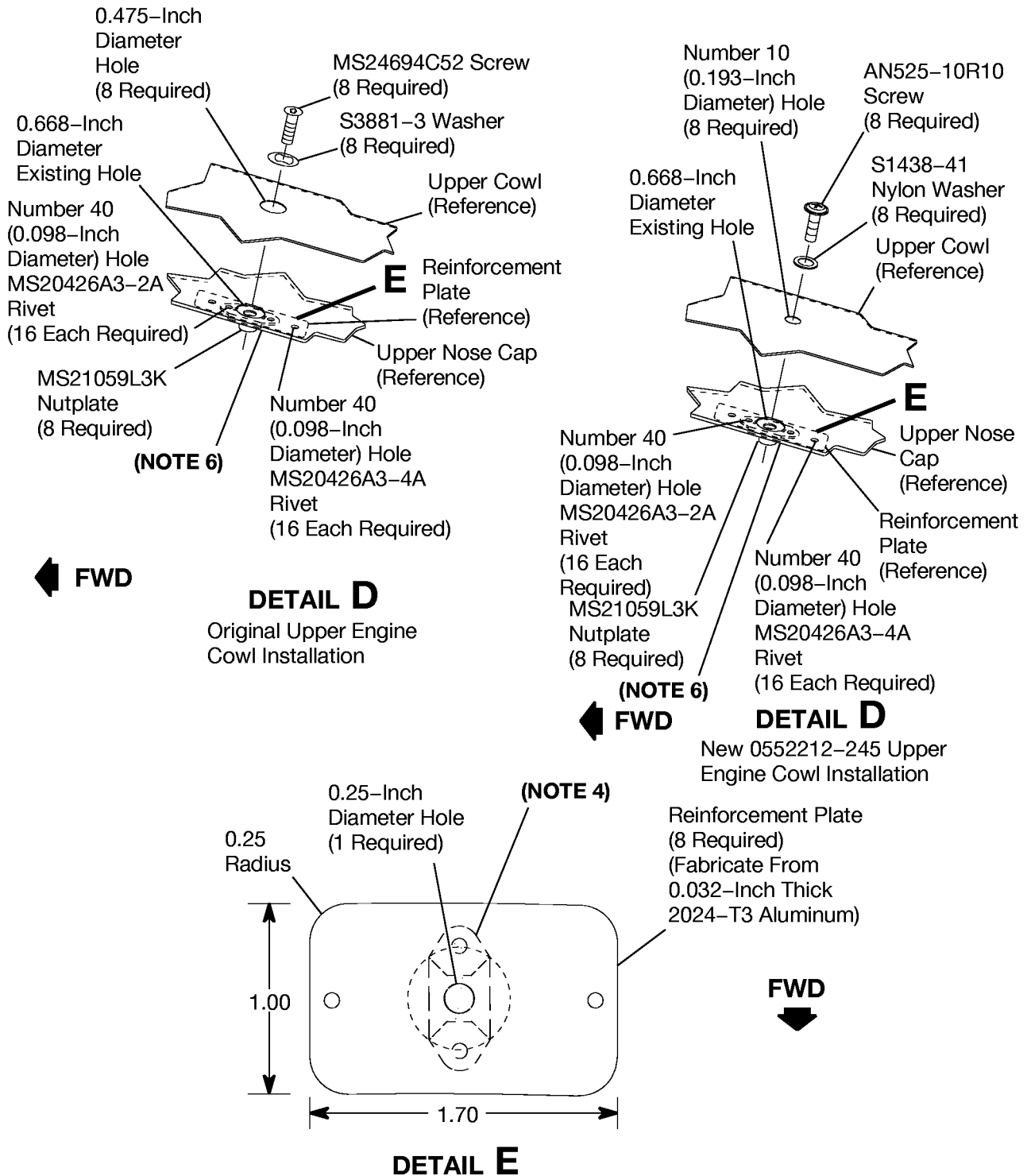

**NOTE 6:** Turn the MS21059L3K nutplate as necessary to align the nutplate and to give an edge distance of no less than two fastener diameters.

0552T237

Figure 1. Cowling Alignment Fit and Clearance (Sheet 4)

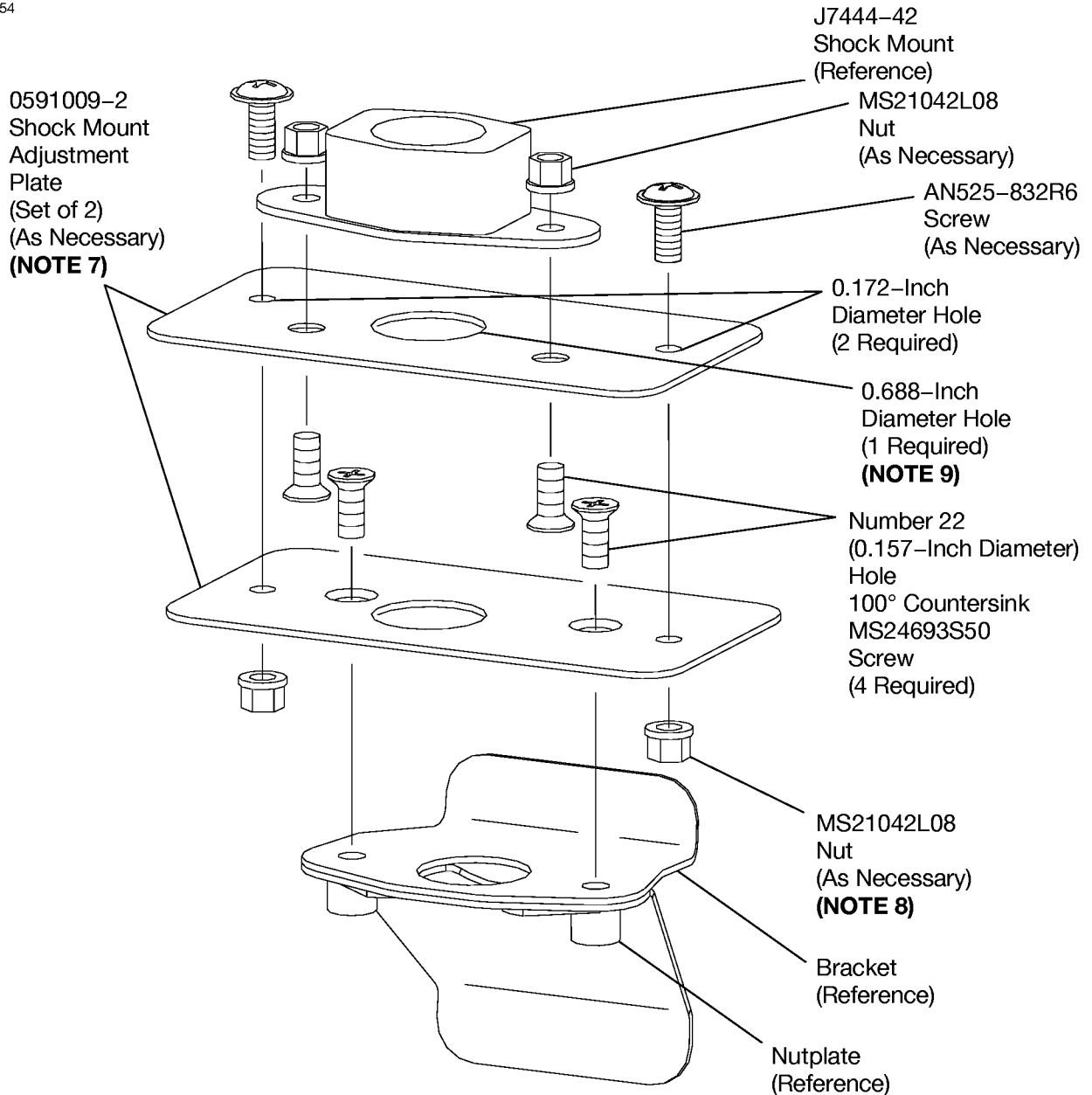

**DETAIL F**  
Shock Mount Adjustment  
Plate Installation

**NOTE 7:** Install 0591009-2 Shock Mount Adjustment Plates so the shock mount can be centered to the S2319 Cowl Fastener.

**NOTE 8:** MS21073L08 Nutplates may be used as an alternate.

**NOTE 9:** Center hole under the shock mount through both 0591009-2 Shock Mount Adjustment Plates.

F0591T0090

Figure 1. Cowling Alignment Fit and Clearance (Sheet 5)

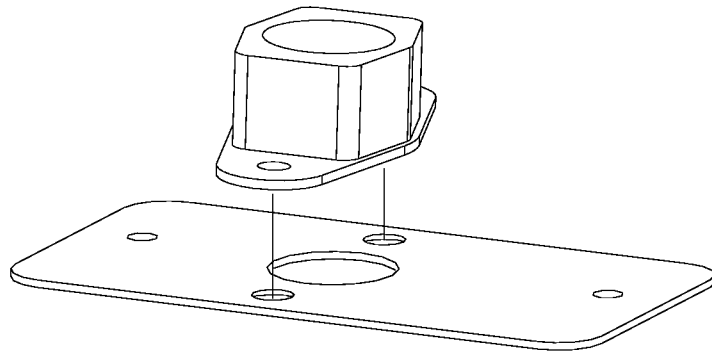

**DETAIL G**  
Mount Locations  
1, 4, 8, and 11  
**(NOTE 10)**

**NOTE 10:** It is permissible to install the shock mount adjustable plates at locations 1, 4, 8, and 11 in the same orientation as shown in Detail G. Remove material from the plates as necessary to get 0.05-inch clearance between the adjustable plates, engine mounts, and firewall.

B3870

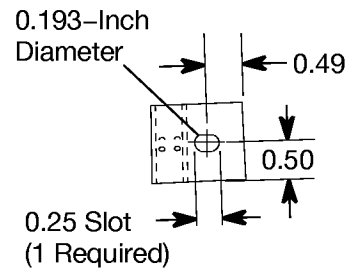
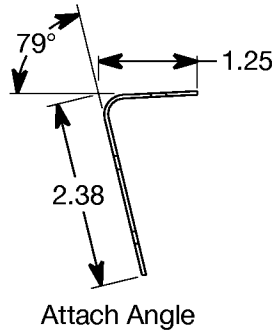
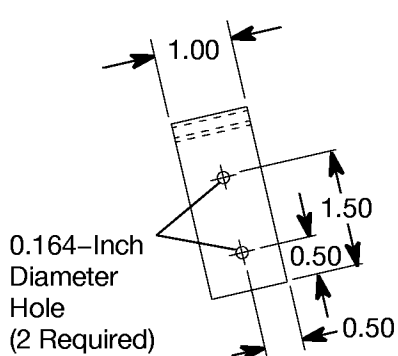
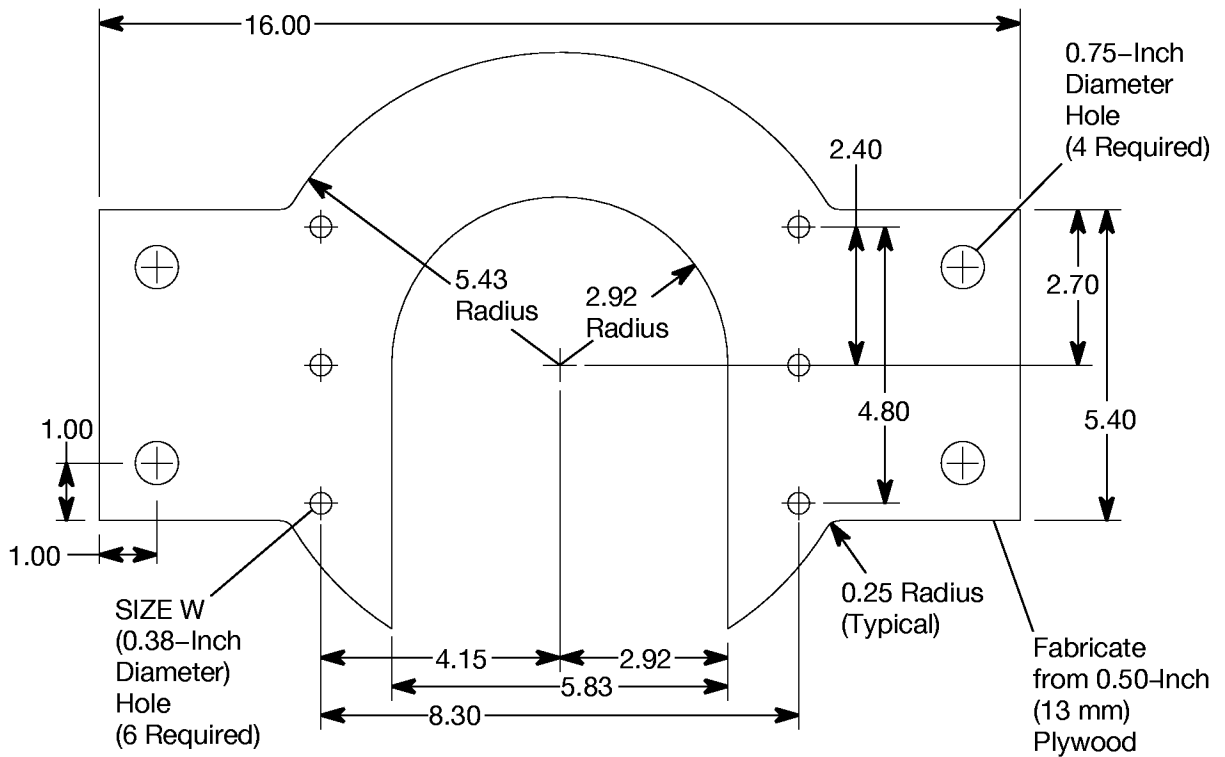
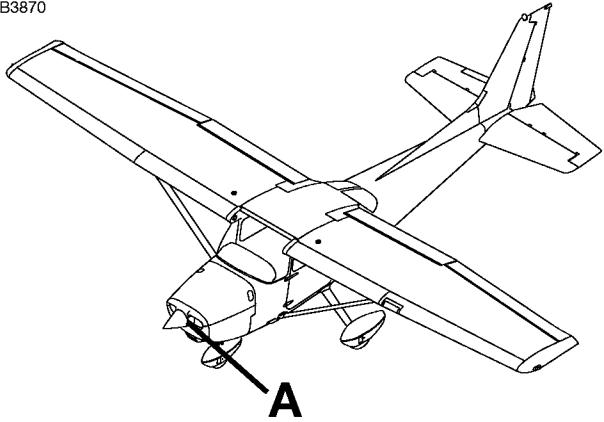

**NOTE:** All dimensions shown are in inches.

**DETAIL A**

Nose Cap Alignment Fixture

Figure 2. Nose Cap Alignment Template (Sheet 1)

B3871

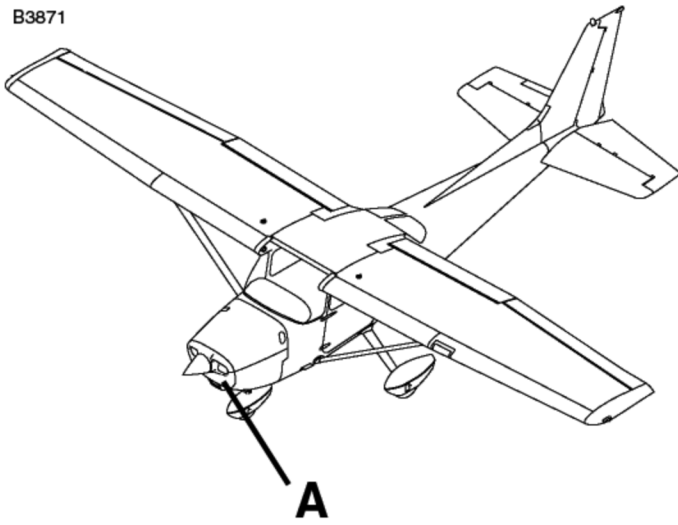

**A**

Nose Cap  
(Reference)

Fabricated  
Nose Cap  
Alignment  
Fixture  
(1 Required)

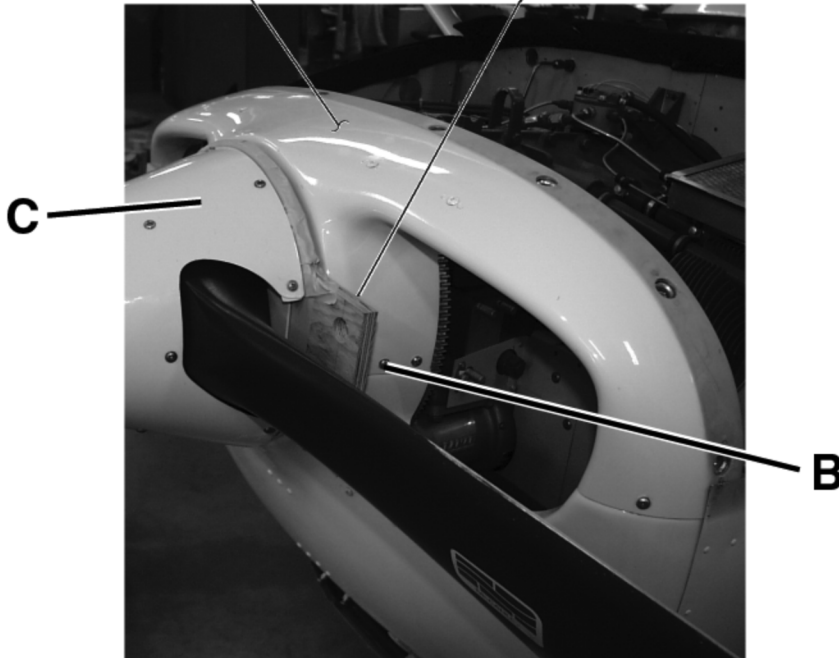

**C**

**B**

**DETAIL A**

Looking Aft on Left Side  
Nose Cap Alignment Fixture

Figure 3. Nose Cap Alignment Fixture Installation (Sheet 1)

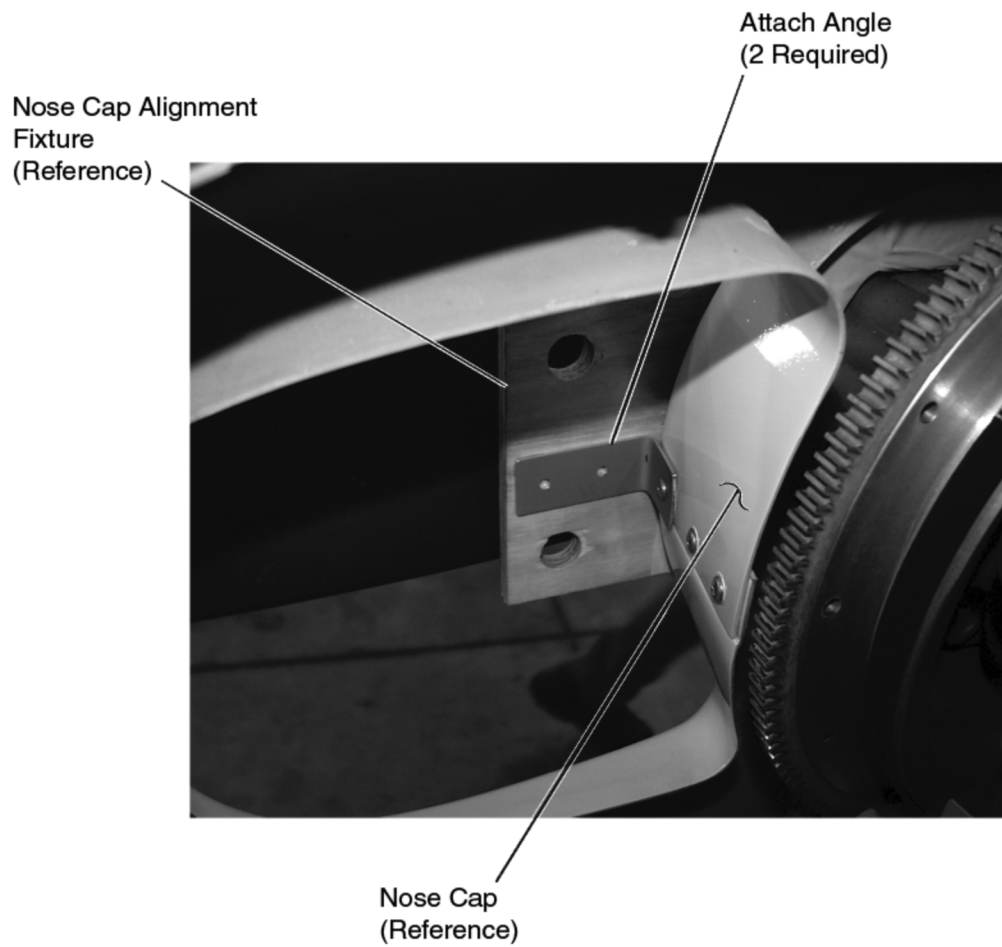

### **DETAIL B**

Looking Forward on Left Side  
Nose Cap Alignment Fixture with Attach Angle

Figure 3. Nose Cap Alignment Fixture Installation (Sheet 2)

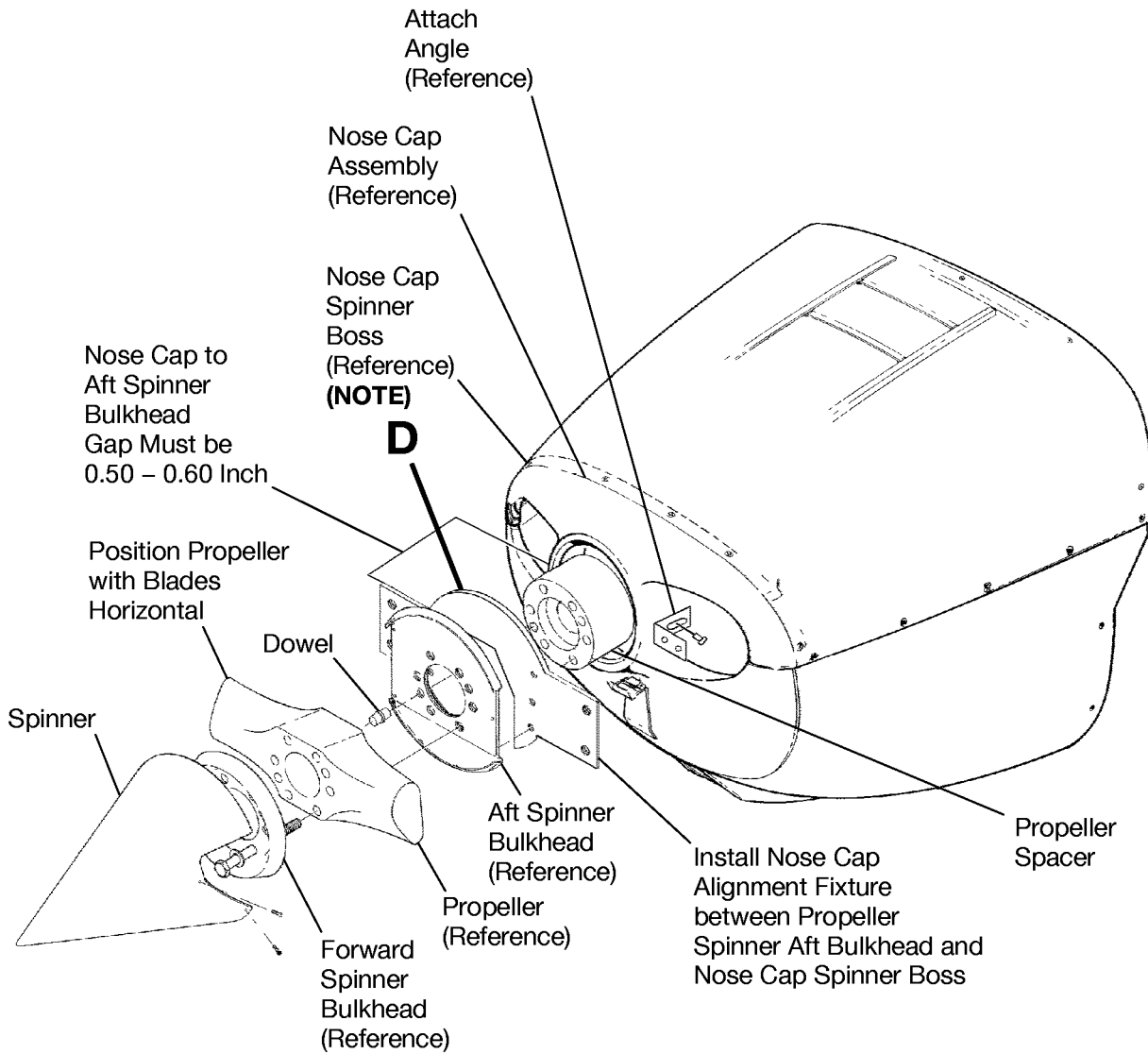

### DETAIL C

Cowl Nose Cap to Propeller Alignment

**NOTE:** The propeller spacer must be centered in the nose cap spinner boss opening.

Figure 3. Nose Cap Alignment Fixture Installation (Sheet 3)

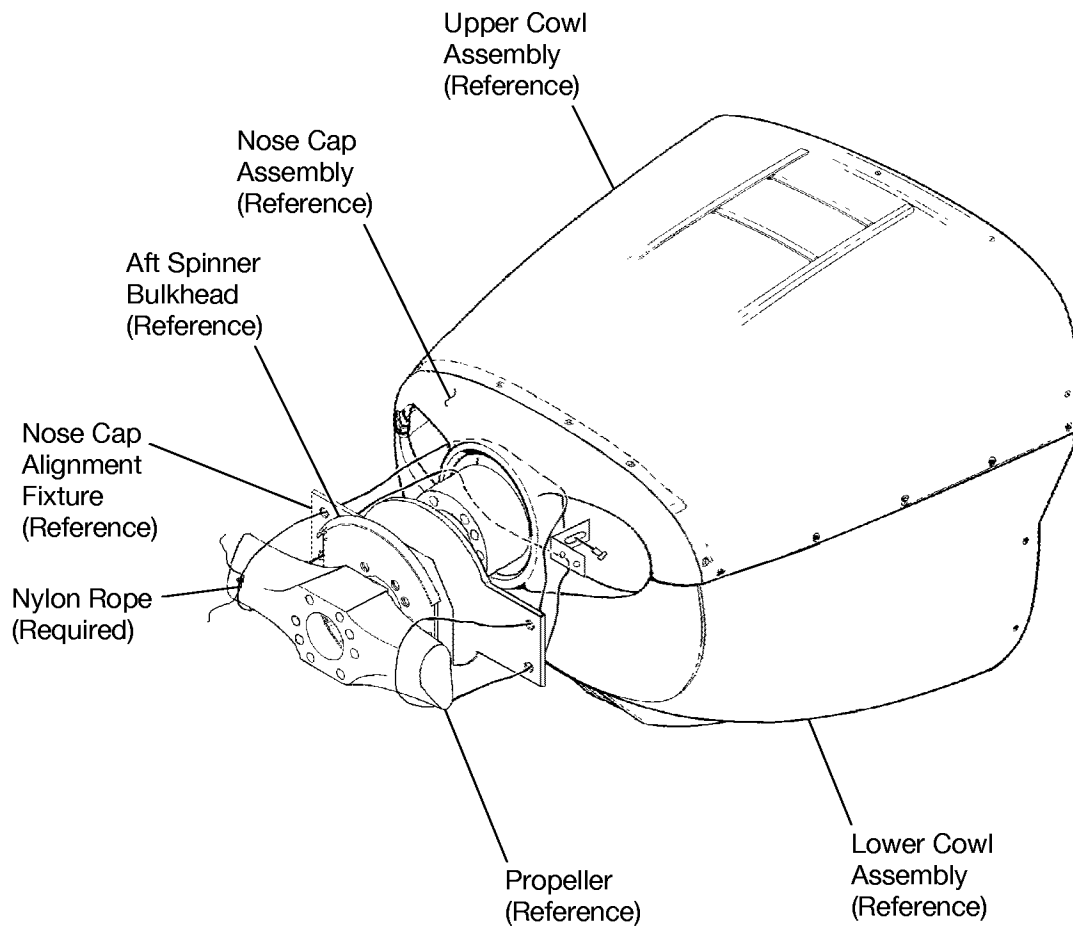

### DETAIL D

Cowl Nose Cap to Spinner Aft Bulkhead Gap Adjustment

Figure 3. Nose Cap Alignment Fixture Installation (Sheet 4)

B4017

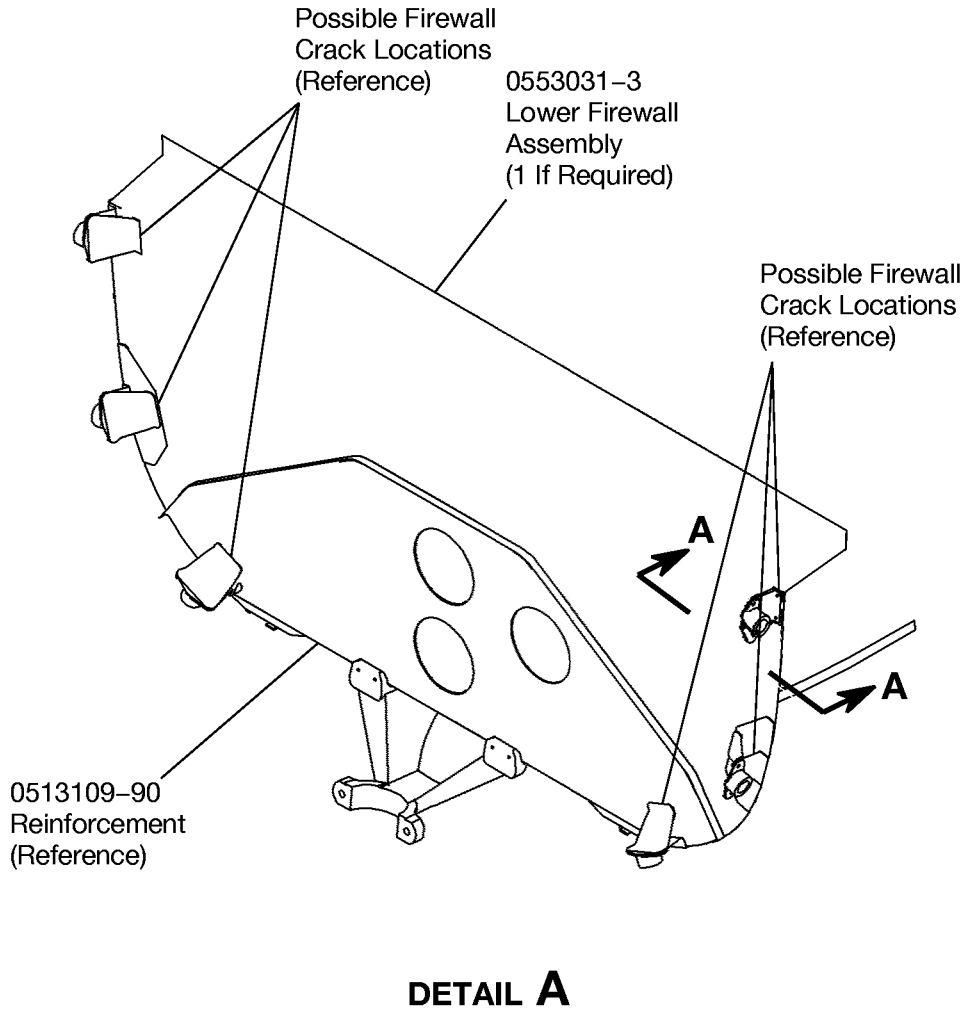
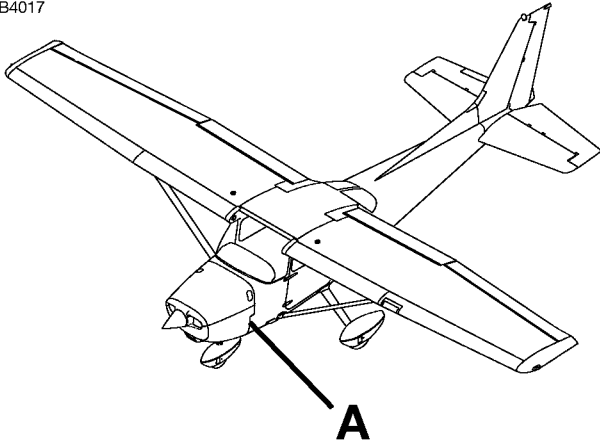
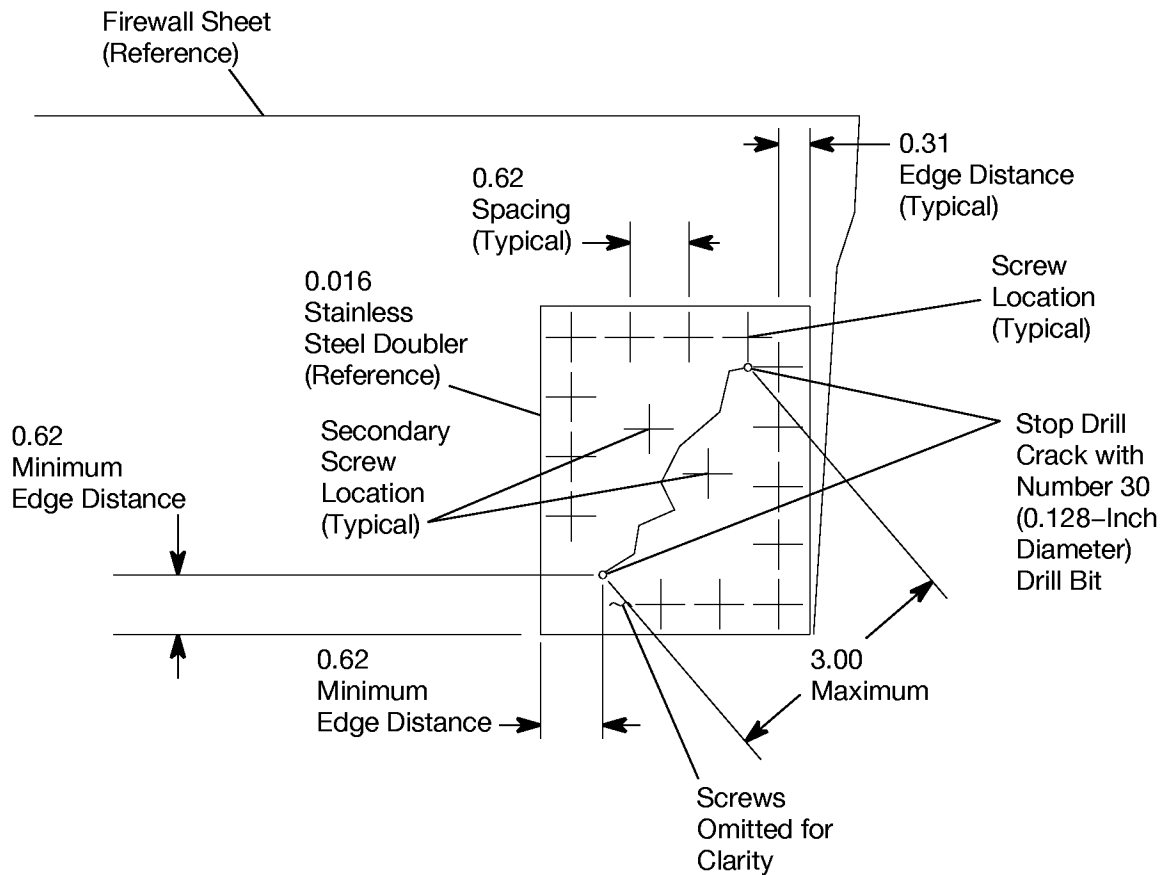

Figure 4. Cowling Alignment Fit and Clearance (Sheet 1)

0510T1007



**VIEW A-A**  
 Typical Doubler  
 Installation Shown

**NOTE:** All dimensions shown are in inches.

Figure 4. Cowling Alignment Fit and Clearance (Sheet 2)

## OWNER NOTIFICATION

On February 8, 2008 the following message will be sent to applicable owners of record in SB08-53-01A.

Dear Cessna Owner:

This Owner Advisory is to inform you that Service Bulletin SB08-53-01 has been issued to provide a more detailed inspection of the engine cowling installation for alignment, fit, and clearance with the fuselage; and for cracks in the firewall. To provide modifications for the cowling shock mount attach brackets and engine baffle seals.

The engine cowling installation and firewall should be inspected and modified as specified in this Service Bulletin.

Compliance is optional; may be accomplished if desired.

### A. Credit Coverage For Airplanes In Warranty

#### Firewall Coverage:

A labor allowance credit of 2.9 man-hours per airplane will be provided to inspect the firewall for cracks.

If necessary, a labor allowance credit of 9.0 man-hours, applicable parts credit, and a miscellaneous parts credit of \$18.00 per repair doubler will be provided to fabricate and install the doubler.

If necessary, an additional labor allowance credit of 4.3 man-hours per repair doubler will be provided to install a repair doubler behind the battery box.

If necessary, a labor allowance credit of 70.0 man-hours, applicable parts credit, and a miscellaneous parts credit of \$12.00 per airplane will be provided to replace the lower firewall.

#### Cowling Installation Coverage:

A labor allowance credit of 14.4 man-hours per airplane will be provided for inspection of the engine cowling alignment and fit, installation of the engine cowling adjustable plates, and installation of nose cap reinforcement plates. Applicable parts credit will be provided.

If the existing upper cowl is retained, a miscellaneous parts credit of \$58.00 per airplane will be provided.

If necessary, a labor allowance credit of 22.6 man-hours per airplane will be provided to replace the upper cowl. Applicable upper cowl parts credit and a miscellaneous parts credit of \$58.00 per airplane will be provided.

B. Credit Coverage For Airplanes Beyond Warranty

Firewall Coverage:

If necessary, applicable parts credit and a miscellaneous parts credit of \$18.00 will be provided per repair doubler to fabricate and install the doubler.

If necessary, applicable parts credit and a miscellaneous parts credit of \$12.00 will be provided per airplane to replace the lower firewall.

Cowling Installation Coverage:

If the existing upper cowl is retained, a miscellaneous parts credit of \$58.00 per airplane will be provided.

If upper cowling replacement is necessary, applicable upper cowl parts credit and a miscellaneous parts credit of \$58.00 per airplane will be provided.

To receive credit, the work must be completed and a Warranty Claim submitted by a Cessna Single Engine Service Station within 30 calendar days of Service Bulletin compliance before the credit expiration dates shown below.

Domestic . . . . . January 28, 2009  
International . . . . . January 28, 2009

The information contained in the referenced Cessna Service Bulletin shall be considered an amendment to the Cessna Manufacturer's Service/Maintenance Manual.

Please contact a Cessna Single Engine Service Station for detailed information and arrange to have Cessna Service Bulletin SB08-53-01 accomplished on your airplane.

\* \* \* \* \*

